

**USE
AND
MAINTENANCE
MANUAL**

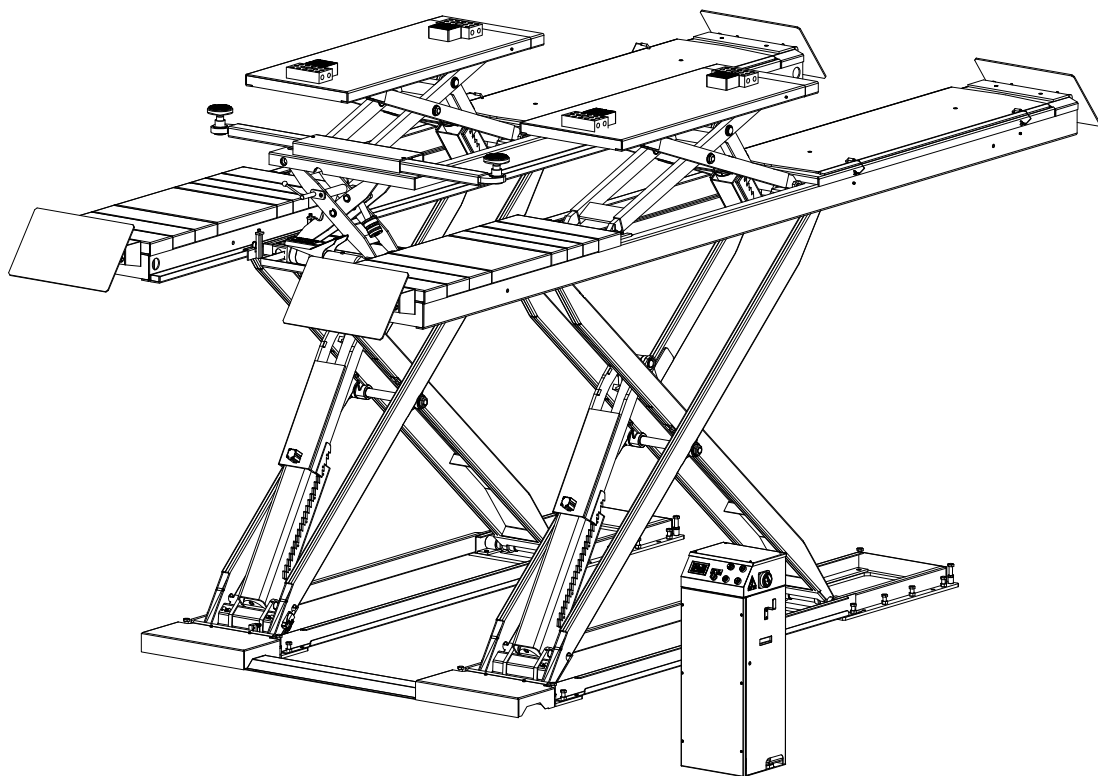



SCISSOR LIFT FOR ALIGNMENT

STD-8240B1



PRINTING CHARACTERS AND SYMBOLS

Throughout this manual, the following symbols and printing characters are used to facilitate reading:

	Indicates the operations which need proper care
	Indicates prohibition
	Indicates a possibility of danger for the operators
	Indicates the direction of access for motor vehicles to the lift
BOLD TYPE	Important information

	WARNING: before operating the lift and carrying out any adjustment, read carefully chapter 7 “installation” where all proper operations for a better functioning of the lift are shown.
---	--

CONTENTS

1	GENERAL INFORMATION	4
2	PRODUCT IDENTIFICATION	6
3	PACKING, TRANSPORT AND STORAGE	7
4	PRODUCT DESCRIPTION	9
5	TECHNICAL SPECIFICATION	11
6	SAFETY	20
7	INSTALLATION	23
8	OPERATION AND USE	32
9	MAINTENANCE	38
10	TROUBLESHOOTING	39

CHAPTER 1 – GENERAL INFORMATION

This chapter contains warning instructions to operate the lift properly and prevent injury to operators or objects.

This manual has been written to be used by shop technicians in charge of the lift (operator) and routine maintenance technician (maintenance operator).

The operating instructions are considered to be an integral part of the machine and must remain with it for its whole useful life.

Read every section of this manual carefully before operating the lift and unpacking it since it gives helpful information about:

- SAFETY OF PEOPLE
- SAFETY OF THE LIFT
- SAFETY OF LIFTED VEHICLES

The company is not liable for possible problems, damage, accidents, etc. resulting from failure to follow the instructions contained in this manual.

Only skilled technicians of **AUTHORISED DEALERS** or **SERVICE CENTRES AUTHORISED** by the manufacturer shall be allowed to carry out lifting, transport, assembling, installation, adjustment, calibration, settings, extraordinary maintenance, repairs, overhauling and dismantling of the lift.

THE MANUFACTURER IS NOT RESPONSIBLE FOR POSSIBLE DAMAGE TO PEOPLE, VEHICLES OR OBJECTS IF SAID OPERATIONS ARE CARRIED OUT BY UNAUTHORIZED PERSONNEL OR THE LIFT IS IMPROPERLY USED.

Any use of the machine made by operators who are not familiar with the instructions and procedures contained herein shall be forbidden.

1.1 MANUAL KEEPING

For a proper use of this manual, the following is recommended:

- keep the manual near the lift, in an easily accessible place.
- keep the manual in an area protected from the damp.
- use this manual properly without damaging it.
- Any use of the machine made by operators who are not familiar with the instructions and procedures contained herein shall be forbidden.

This manual is an integral part of the lift: it shall be given to the new owner if and when the lift is resold.

1.2 OBLIGATION IN CASE OF MALFUNCTION

	In case of machine malfunction, follow the instructions contained in the following chapters.
---	---

1.3 CAUTIONS FOR THE SAFETY OF THE OPERATOR

Operators must not be under the influence of sedatives, drugs or alcohol when operating the machine.

	Before operating the lift, operators must be familiar with the position and function of all controls, as well as with the machine features shown in the chapter “Operation and use”
---	--

1.4 WARNINGS

	Unauthorized changes and/or modifications to the machine relieve the manufacturer of any liability for possible damages to objects or people. Do not remove or make inoperative the safety devices, this would cause a violation of safety at work laws and regulations.
---	---

	Any other use which differs from that provided for by the manufacturer of the machine is strictly forbidden.
---	---

	The use of non genuine parts may cause damage to people or objects
--	---

1.5 SCRAPPING

When your machine’s working life is over and it can no longer be used, it must be made inoperative by removing any connection to power sources.

These units are considered as special waste material, and should be broken down into uniform parts and disposed of in compliance with current laws and regulations.

If the packing are not polluting or non-biodegradable, deliver them to appropriate handling station.

DECLARATION OF WARRANTY AND LIMITATION OF LIABILITY

The manufacturer has paid proper attention to the preparation of this manual. However, nothing contained herein modifies or alters, in any way, the terms and conditions of manufacturer agreement by which this lift was acquired, nor increase, in any way, manufacturer’s liability to the customer.

TO THE READER

Every effort has been made to ensure that the information contained in this manual is correct, complete and up-to date. The manufacturer is not liable for any mistakes made when drawing up this manual and reserves the right to make any changes due the development of the product, at any time.

CHAPTER 2 – PRODUCT IDENTIFICATION

The identification data of the machine are shown in the label placed on the control unit.

LOGO	
Type:
Model:
Serial Number:
Year of manufacturing:
Capacity:
Voltage:
Power:

 **Use the above data both to order spare parts and when getting in touch with the manufacturer (inquiry). The removal of this label is strictly forbidden.**

Machines may be updated or slightly modified from an aesthetic point of view and, as a consequence, they may present different features from these shown, this without prejudicing what has been described herein.

2.1 WARRANTY CERTIFICATE

The warranty is valid for a period of 12 months starting from the date of the purchase invoice.

The warranty will come immediately to an end when unauthorized modifications to the machine or parts of it are carried out.

The presence of defects in workmanship must be verified by the Manufacturer's personnel in charge.

2.2 TECHNICAL SERVICING

For all servicing and maintenance operations not specified or shown in these instructions, contact your Dealer where the machine has been bought or the Manufacturer's Commercial Department.

Only skilled personnel who are familiar with the lift and this manual shall be allowed to carry out packing, lifting, handling, transport and unpacking operations.

CHAPTER 3 - PACKING, TRANSPORT AND STORAGE

3.1 PACKING

The packing of the lift is delivered in following components:

- No. 2 base units, each one with a runway equipped with 2 hydraulic cylinders
- No. 1 jack beam with an air pedal pump
- No. 1 control unit and containing hydraulic unit, hydraulic hoses, air hoses, anchor bolts, rubber blocks and the technical files c
- No. 2 turntable recess covers
- No. 2 drive-on ramps, 2 drive-off ramps, and 4 hose protective covers if the lift is ordered for on-floor installation

(If requested, optional accessories are available to satisfy each customer's requirements).

3.2 LIFTING AND HANDLING

When loading/unloading or transporting the equipment to the site, be sure to use suitable loading (e.g. cranes, trucks) and hoisting means. Be sure also to hoist and transport the components securely so that they cannot drop, taking into consideration the package's size, weight and centre of gravity and its fragile parts.

In figure 1 there are the correct indications for the lifting of the runways:



Figure 1 – LOADING/UNLOADING RUNWAY

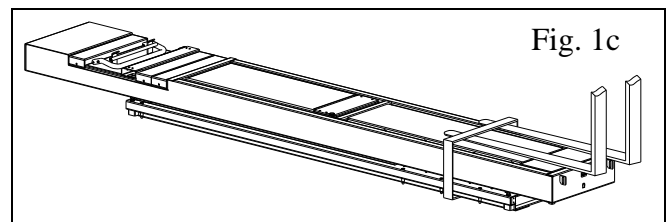
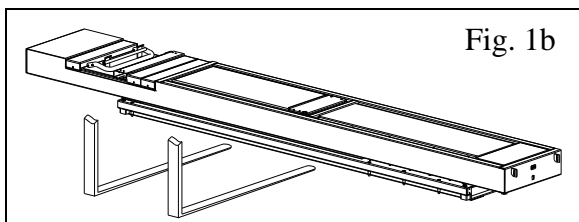
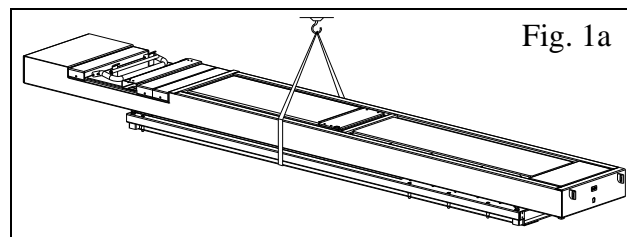

3.3 STORAGE AND STACKING OF PACKAGES

Packages must be stored in a covered place, out of direct sunlight and in low humidity, at a temperature between -10°C and +40°C.

Stacking is not recommended: the package's narrow base, as well as its considerable weight and size make it difficult and hazardous.

3.4 DELIVERY AND CHECK OF PACKAGES

When the lift is delivered, check for possible damages due to transport and storage; verify that what is specified in the manufacturer's confirmation of order is included. In case of damage in transit, the customer must immediately inform the carrier of the problem.

Packages must be opened paying attention not to cause damage to people (keep a safe distance when opening straps) and parts of the lift (be careful the objects do not drop from the package when opening).

CHAPTER 4 - PRODUCT DESCRIPTION

4.1 LIFT DESCRIPTION (Ref. Figure 2)

This lift has been designed for the lifting of motor-vehicles for wheel alignment and maintenance. The lift can be mounted either on surface or in pit (flush mounted).

The maximum lifting weight is as specified on the serial plate.

All mechanical frames, such as platforms, extensions, base frames and arms have been built in steel plate to make the frame stiff and strong while keeping a low weight

The electro hydraulic operation is described in detail in chapter 8.

This chapter describes the lift's principal elements, allowing the user to be familiar with the machine. As shown in figure 2, the lift is composed of two runways: P1(1) and P2 (2) with two wheel free jacks (3), anchored to the ground by means of its base (4).

At a special request, one jack beam (5) can be supplied and operated by an air-hydraulic pedal pump.

Runways are linked to the base by means of a scissors lifting system.

The lifting system of each runway is composed of scissor arms (6) and a hydraulic cylinder (7).

Turntable recess cover (8) is supplied with the lift in case for non-alignment purpose.

Lifting and lowering motion of lift and wheel free jacks is carried out by operation of a control unit (9) placed next to the lift.

The leveling system of the lift is carried out manually by operation of the leveling cocks in the power unit.

The mechanical safety operating by a pneumatic cylinder (10) is built under each runway and wheel free jack for engagement and release.

Two limit switches are installed in the P1 base: for top position limit and for the safety height limit.

The photocells (11) are located in the platforms to check the synchronization of the platforms.

Figure 2 – LIFT

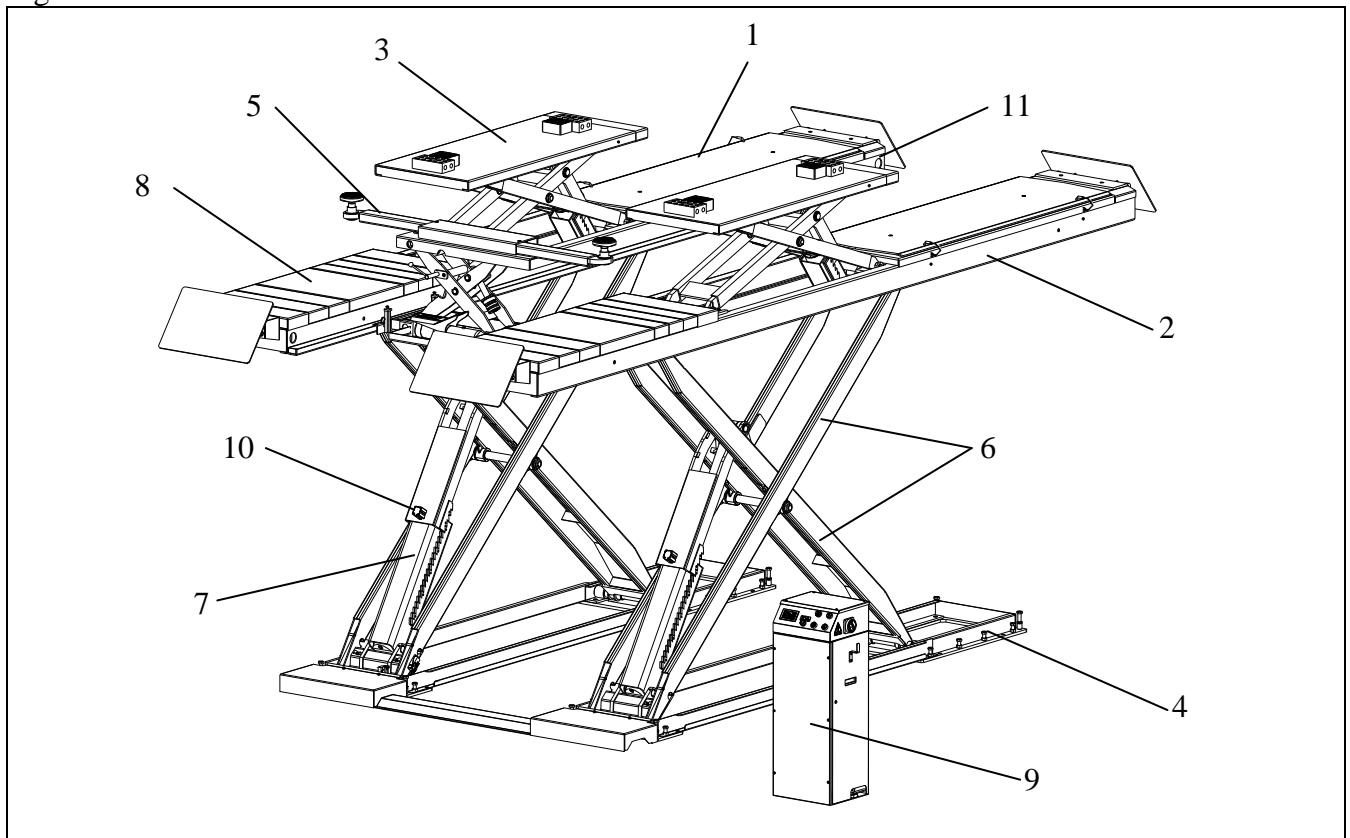

4.2 OPERATION

Platform lifting is carried out by the hydraulic unit which acts upon the cylinders.

The platforms are raised simultaneously owing cross feeding of the hydraulic cylinders.

Lowering, even though electrically controlled, is carried out by the weight of both the platforms and the load lifted.

Lowering motion of the wheel free jacks with load less can be sped up by means of pneumatic action in the chamber of its slave cylinder.

The hydraulic system is protected by a max pressure valve thus preventing pressure from exceeding the maximum fixed safety limit.

The hydraulic system is protected by a max pressure valve thus preventing pressure from exceeding the maximum fixed safety limit.

The synchronization of the platforms is guaranteed by a master/slave circuit and controlled by photocells.

Whenever the lift has to be lowered to the ground and the lowering button is pressed, the lift will stop at about *400 mm* from the ground.

In this way, the operator must verify that neither persons nor objects are within the safety area

If so, the final lowering button can be pressed and the lift be lowered. A beep sound is heard during the last travel.

CHAPTER 5 - TECHNICAL SPECIFICATION

5.1 SIZE AND MAIN FEATURES (Ref. Figure 3)

CAPACITY	4000KG
Capacity of wheel free jacks	4000kg
Capacity of jacking beam	2500kg
Max. primary lifting height	2160mm
Max. secondary lifting height	430mm
Jack beam lifting height with no extension	22 - 428mm
Min. lowered height	290mm
Length of the runway	4800mm
Adjusted length of the wheel free jack table	1500 – 2000mm
Adjusted length of the jack beam arm	766 – 1626mm
Width of platform	608mm
Suggested free width between runways	997 mm
Lifting time	60 s
Lowering time	60 s
Compressed air pressure	6 bar – 8 bar
Noise level	80 dB(A)/1m
Working temperature	-10 °C - 40 °C
Package weight	2610kg including all

5.2 ELECTRIC MOTOR

Type	ML90L2	TP90L4
Voltage	230V/220V-1Ph	400V/380V-3Ph
Power	2.2 KW	2.6 KW
N° Poles	2	4
Speed	2800 rpm	1375 rpm
Motor enclosure type	B14	
Insulation class	IP 54	

Motor connection must be carried out referring to the attached wiring diagrams (figure 6).

The motor direction of rotation is shown in the label placed on the motor.

Before use of the lift, make sure to check if the motor specification shown in the nameplate of the motor conforms to the local electric supply.

If there is over 10% fluctuation on the electrical power supply, it is suggested to use the voltage stabilizer to protect the electrical components and system from overloading.

5.3 PUMP

Type	Gear	
Flow rate	2.1 cm ³ /g	4.8 cm ³ /g
Continuous working pressure	230 bar – 240 bar	
Peak pressure	270 bar	

Figure 3a – LAYOUT FOR IN-GROUND INSTALLATION

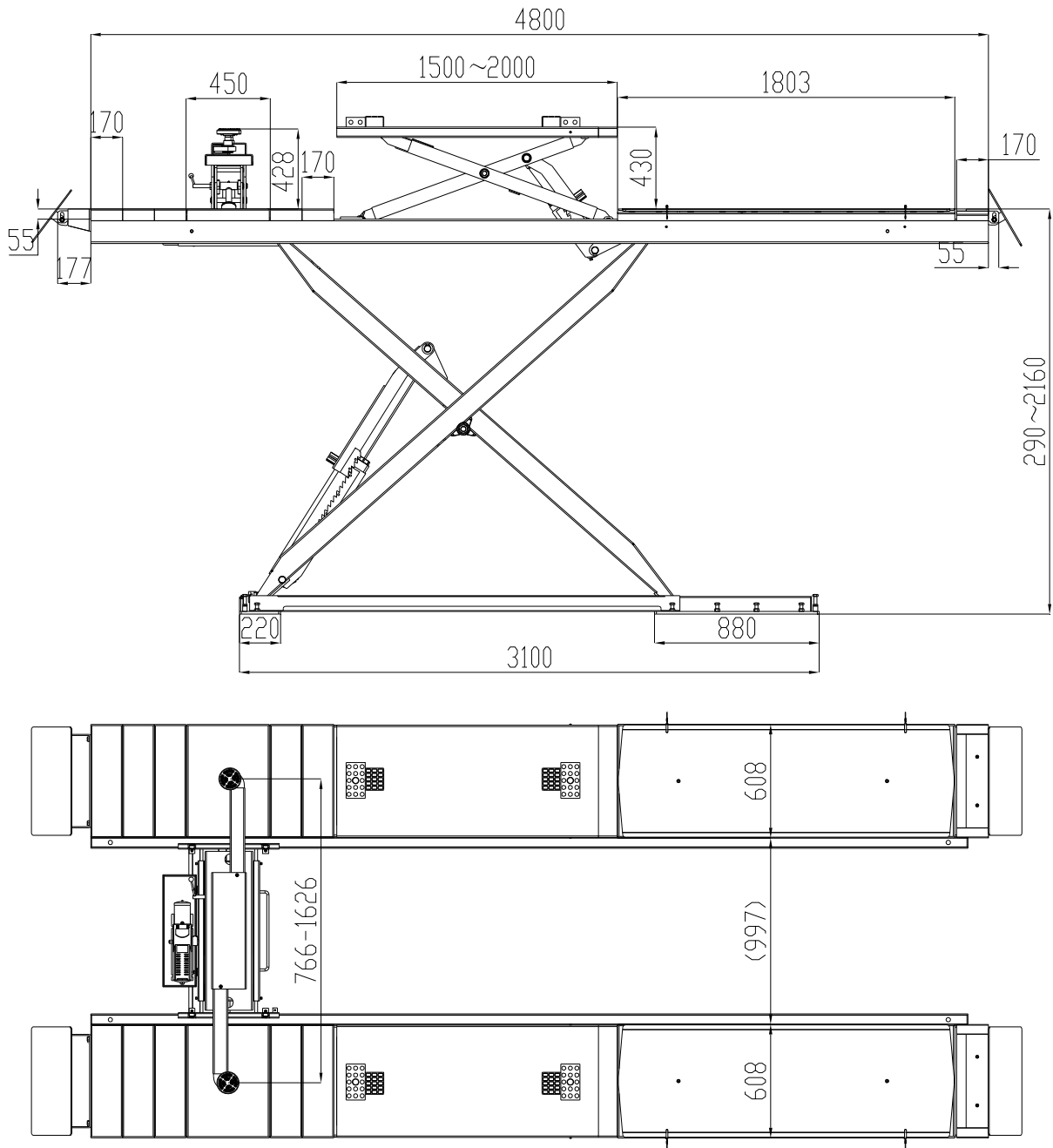
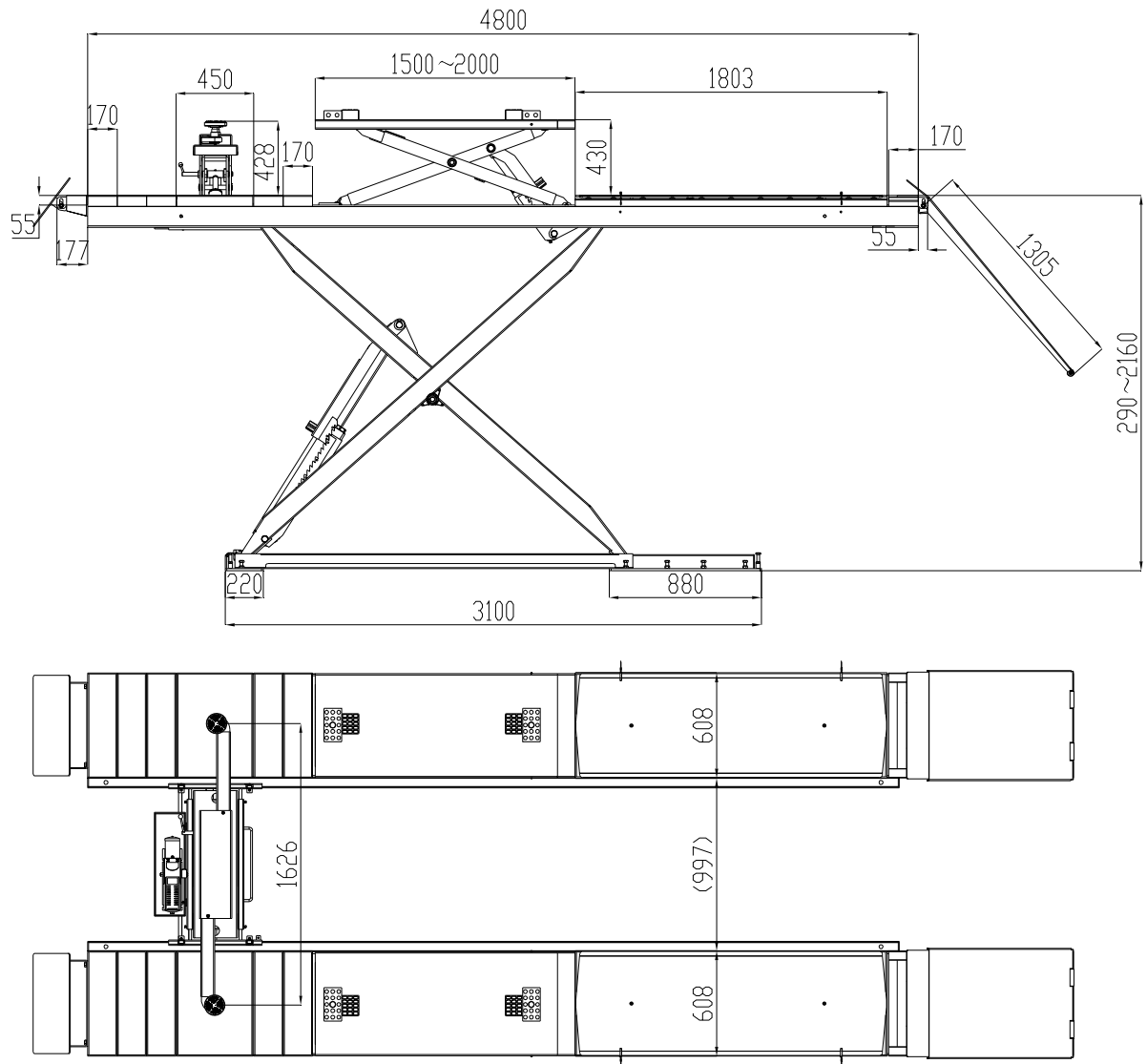

Figure 3b – LAYOUT FOR ON-GROUND INSTALLATION



5.4 HYDRUALIC UNIT

Figure 4 – HYDRAULIC POWER UNIT

The hydraulic power unit is equipped with

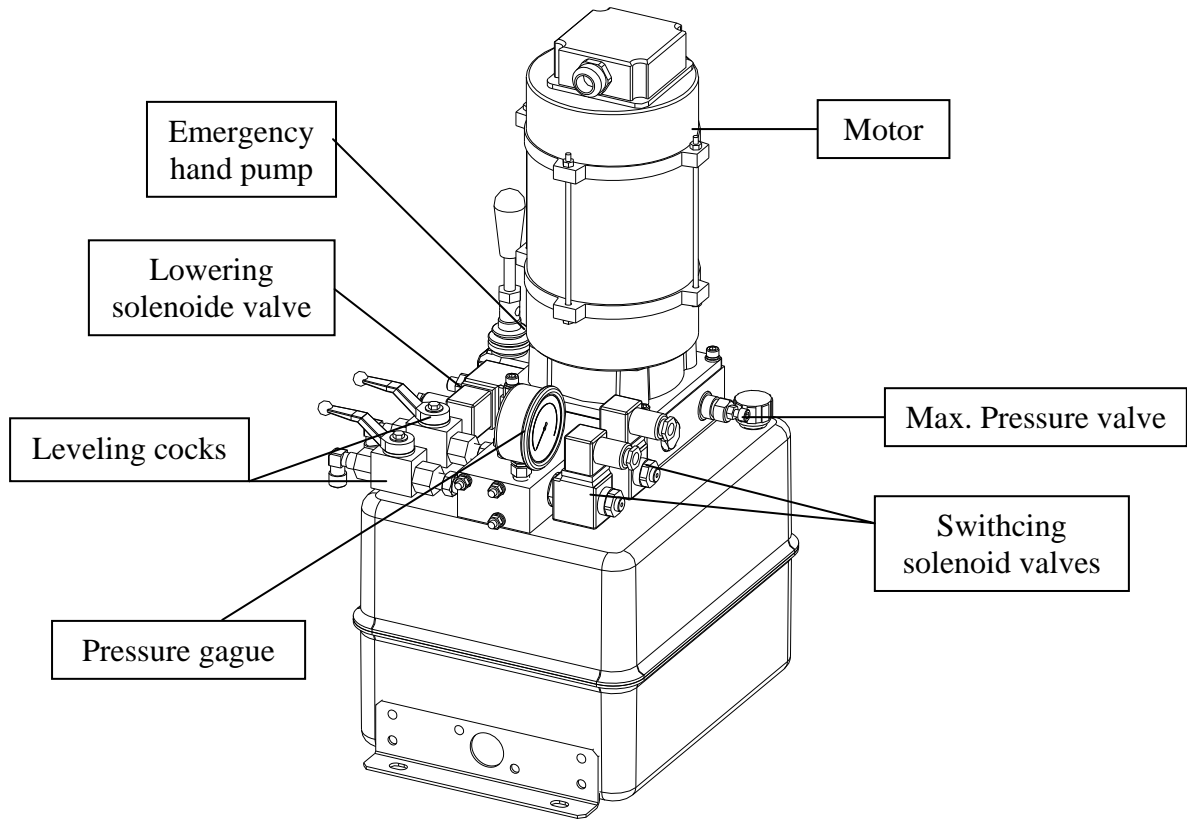

5.5 OIL

Use wear proof oil for hydraulic drive, in conformity with *ISO 6743/4* rules (HM class). The oil with features similar to those shown in the table is recommended.

TEST STANDARDS	FEATURES	VALUE
ASTM D 1298	Density 20°C	0.8 kg/l
ASTM D 445	Viscosity 40°C	32 cSt
ASTM D 445	Viscosity 100°C	5.43 cSt
ASTM D 2270	Viscosity index	104 N°
ASTM D 97	Pour point	~ 30 °C
ASTM D 92	Flash point	215 °C
ASTM D 644	Neutralization number	0.5 mg KOH/g

	CHANGE HYDRAULIC OIL AT 1 YEAR INTERVALS
---	---

Figure 5 – HYDRAULIC PLAN

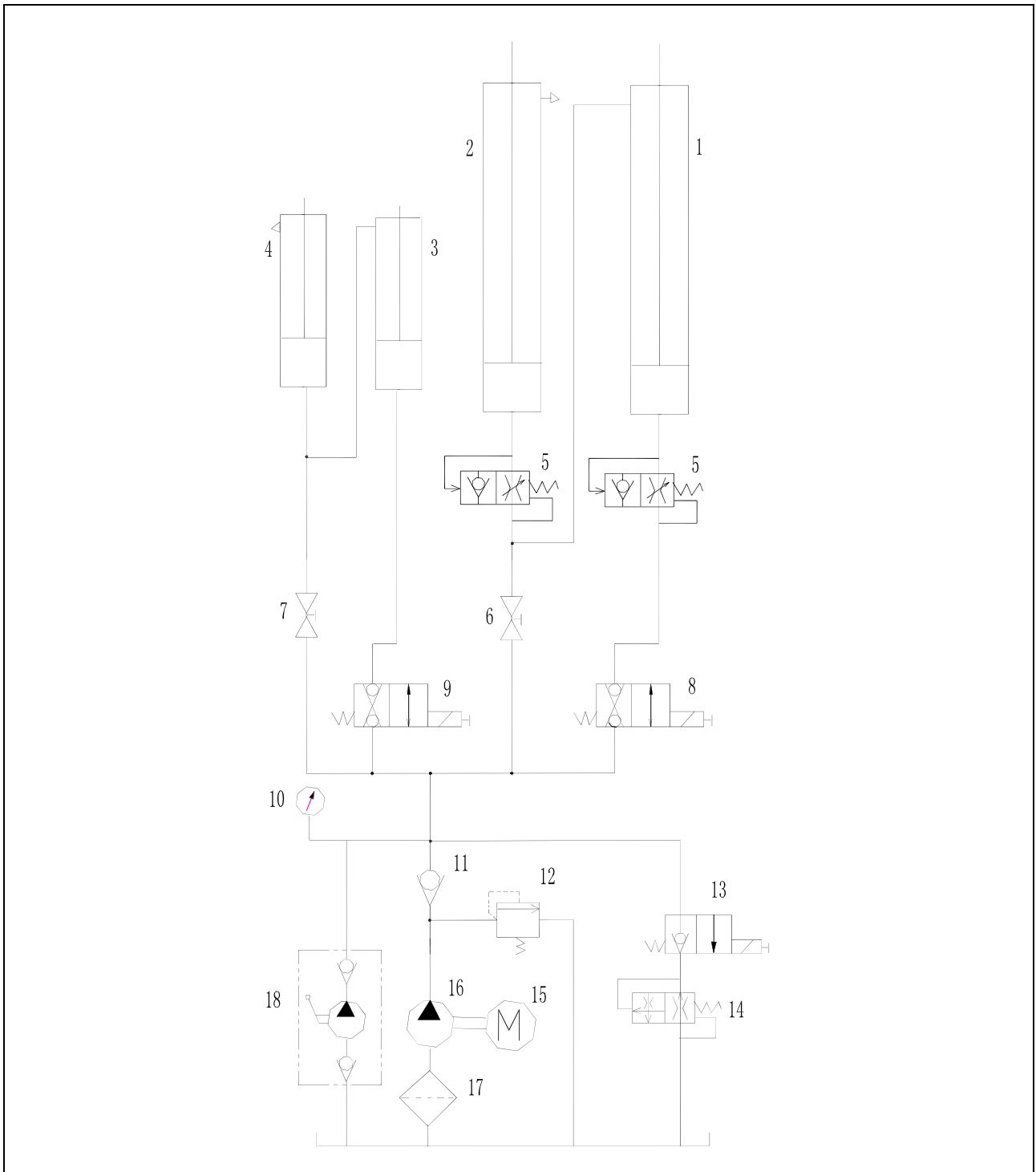

1	Master runway cylinder P1	10	Pressure gauge
2	Slave runway cylinder P2	11	Non return valve
3	P2 jack cylinder	12	Pressure overload valve
4	P1 jack cylinder	13	Lowering solenoid valve
5	Parachute valves	14	Lowering control valve
6	Leveling cock 1 - runways	15	Motor
7	Leveling cock 2 - jacks	16	Gear pump
8	Switching solenoid valve - runways	17	Oil filter
9	Switching solenoid valve - jacks	18	Emergency hand pump

Figure 6a – ELECTRICAL PLAN (400V/230V - 3PH)

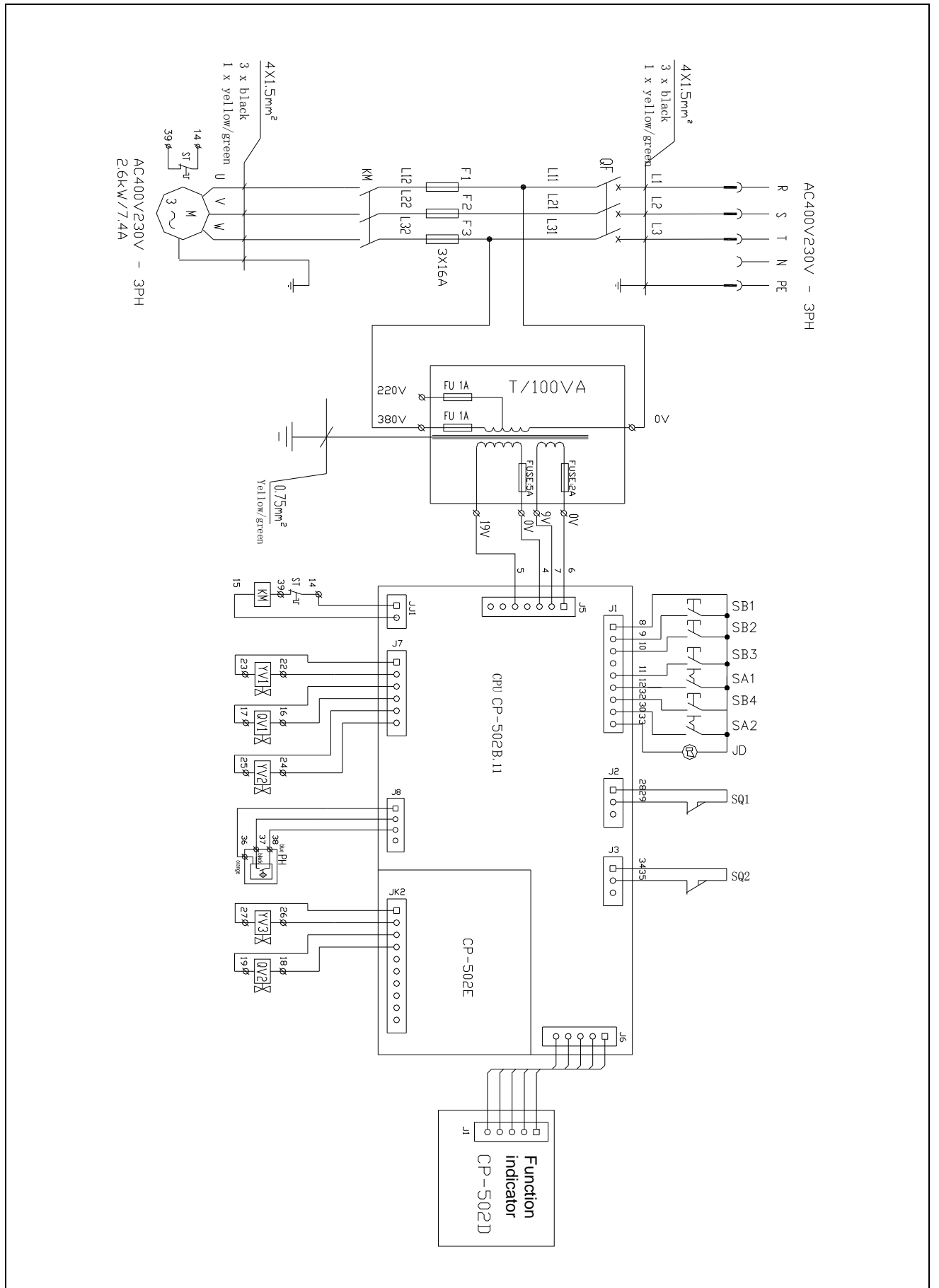
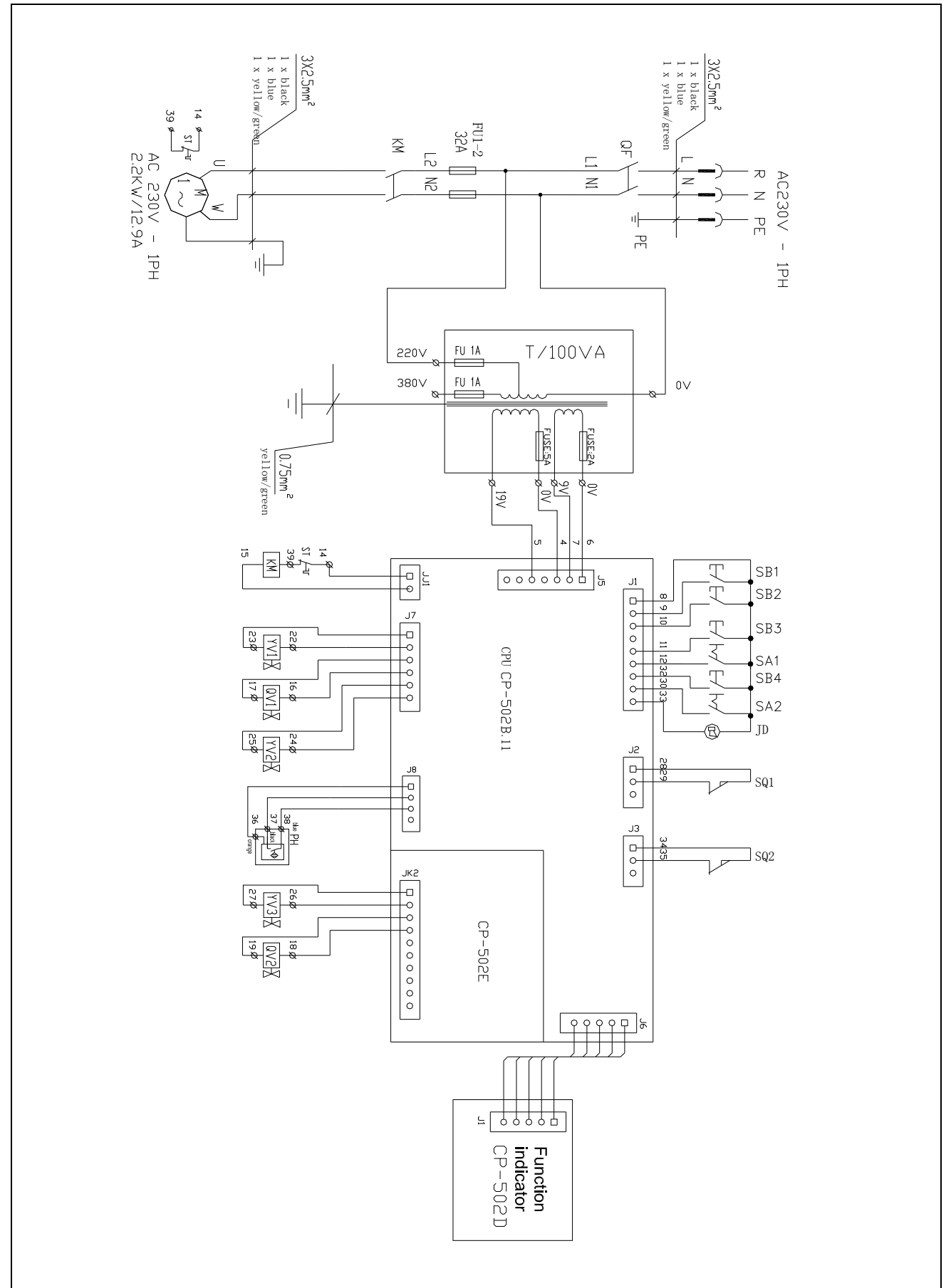
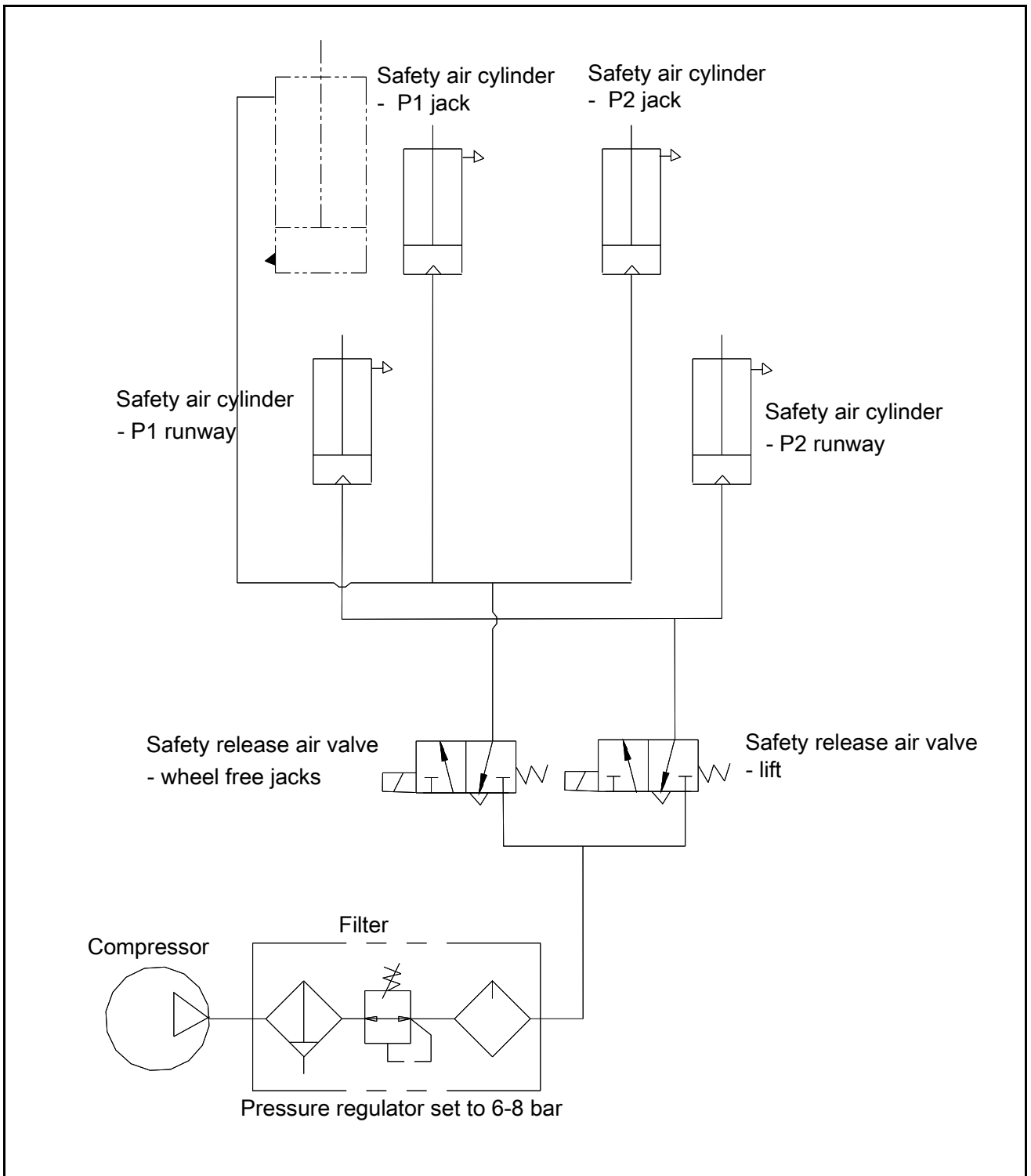



Figure 6b – ELECTRICAL PLAN (230V - 1PH)



QF	Power switch
M	Motor
ST	Thermal relay
T	Transformer 100VA
KM	Contactora DC
SB1	Lifting button
SB2	Lowering/final lowering button
SB3	Safety engaging button
SB4	Photocell pass-by button
SA1	MAIN/JACK selector
SA2	WORK/ADJ selector
JD	Beeper
SQ1	Top limit switch
SQ2	Safety height limit switch
YV1	Lowering solenoid valve
YV2	Switching solenoid valve - runways
YV3	Switching solenoid valve – wheel free jacks
QV1	Safety air valve - runways
QV2	Safety air valve - wheel free jacks
PH	Photocell

Figure 7 – PNEUMATIC PLAN



	<p>Filter/ regulator is not supplied by the manufacturer if no special order.</p>
---	--

CHAPTER 6 – SAFETY

Read this chapter carefully and completely because it contains important information for the safety of the operator and the person in charge of maintenance.

	<p>The lift has been designed and built for lifting vehicles and making them stand above level in a closed area. any other use is forbidden:</p> <p>The manufacturer is not liable for possible damages to people, vehicles or objects resulting from an improper or unauthorized use of the lift.</p>
---	--

For operator and people safety, the safety area shown in Figure 8 must be vacated during lifting and lowering. The lift must be operated only from the operator's control site, as shown. Operator's presence under the vehicle, during working, is only admitted when the vehicle is lifted and platforms are not running

	<p>Never use the lift when safety devices are off-line. People, the lift and the vehicles lifted can be seriously damaged if these instructions are not followed.</p>
---	--

Figure 8 - SAFETY AREA



SAFETY AREA (min. 1 meter)

6.1 GENERAL WARNINGS

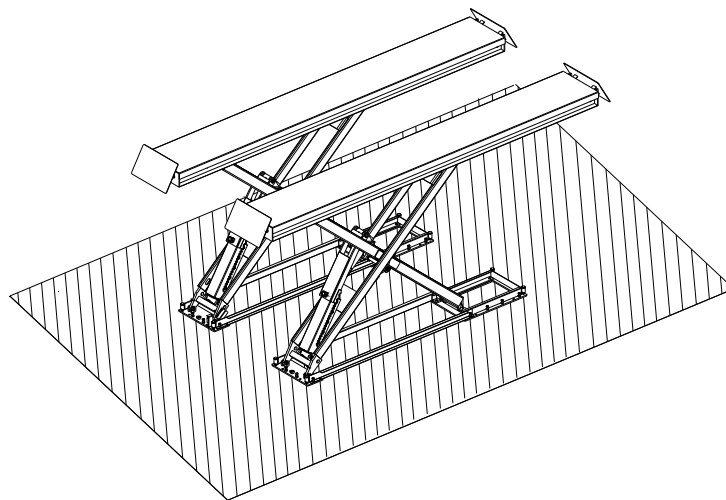
The operator and the person in charge of maintenance must follow accident-prevention laws and rules in force in the country where the lift is installed

They also must carry out the following:

- neither remove nor disconnect hydraulic, electric or other safety devices;
- carefully follow the safety indications applied on the machine and included in the manual;
- observe the safety area during lifting;
- be sure the motor of the vehicle is off, the gear engaged and the parking brake put on;
- be sure only authorized vehicles are lifted without exceeding the maximum lifting capacity;
- Verify that no one is on the platforms during lifting or standing.

6.2 RISKS FOR PEOPLE

All risks the personnel could run, due to an improper use of the lift, are described in this section.

6.3 PERSONNEL CRUSHING RISKS

During lowering of runways and vehicles, personnel must not be within the area covered by the lowering trajectory. The operator must be sure no one is in danger before operating the lift.



Fig. 9a



Fig. 9b



Fig. 9c

6.4 BUMPING RISK

When the lift is stopped at relatively low height for working, the risk of bumping against projecting parts occurs.



Fig. 10

6.5 RISK OF THE VEHICLE FALLING FROM THE LIFT

Vehicle falling from the lift can be caused when the vehicle is improperly placed on platforms, and when its dimensions are incompatible with the lift or by excessive movement of the vehicle. In this case, keep immediately away from the working area.



Fig. 11a



Fig. 11b



Fig. 11c

6.6 SLIPPING RISKS

The risk of slipping can be caused by oil or dirt on the floor near the lift.



Fig. 12



Keep the area under and around the lift clean. Remove all oil spills.

6.7 ELECTROCUTION RISKS

Avoid use of water, steam, and solvent, varnish jets in the lift area where electric cables are placed and, in particular, next to the electric panel.

6.8 RISKS RESULTING FROM IMPROPER LIGHTING

Make sure all areas next to the lift are well and uniformly lit, according to local regulations.

6.9 RISKS OF BREAKING COMPONENT DURING OPERATION

Materials and procedures, suitable for the designed parameters of the lift, have been used by the manufacturer to build a safe and reliable product. Operate the lift only for the use it has been designed for and follow the maintenance schedule shown in the chapter “Maintenance”.



Fig. 13

6.10 RISKS FOR UNAUTHORIZED USES

The presence of unauthorized persons next to the lift and on the platforms is strictly forbidden during lifting as well as when the vehicle has been already lifted



Fig. 14



Any use of the lift other than that herein specified can cause serious accidents to people in close proximity of the machine.

6.11 RISKS DURING VEHICLE LIFTING

To avoid overloading and possible breaking, the following safety devices have been used:

- a maximum pressure valve placed inside the hydraulic unit to prevent excessive weight.
- a special design of the hydraulic system, in case of pipeline failure, to prevent sudden lift lowering..



The maximum pressure valve has been preset by the manufacturer to a proper pressure. DO NOT try to adjust it to overrun the rated lifting capacity.

CHAPTER 7 – INSTALLATION



Only skilled technicians, appointed by the manufacturer, or by authorized dealers, must be allowed to carry out installation. Serious damage to people and to the lift can be caused if installations are made by unskilled personnel.

7.1 CHECKING FOR ROOM SUITABILITY

The lift has been designed to be used in covered and sheltered places free of overhead obstructions. The place of installation must not be next to washing areas, painting workbenches, solvent or varnish deposits. The installation near to rooms, where a dangerous situation of explosion can occur, is strictly forbidden. The relevant standards of the local Health and Safety at Work regulations, for instance, with respect to minimum distance to wall or other equipment, escapes and the like, must be observed.

7.2 LIGHTING

Lighting must be carried out according to the effective regulations of the place of installation. All areas next to the lift must be well and uniformly lit.

7.3 INSTALLATION FOUNDATION

The lift must be placed on a C25 concrete floor, 15cm thick at least, and in conformity with local regulations.

If a floor covering with the above mentioned requirements is not available, a foundation plate is needed or, some fixing points should be used, for fixing areas at least, having sufficient size and thickness (made of concrete of the same quality, as shown).

The surface where the lift has to be installed must be even and leveled in all directions. An inclination not higher than 2 cm in drive-on lift direction and 1 cm cross-wise can be balanced with leveling wedges.

If an installation is made in a hole, the real side of the hole must be verified (as per drawing sent at the order). For installation on raised surface, the compliance with the maximum carrying capacity of the surface is recommended.

Floor fixing is the same both in on-floor and in-ground installations.

The new concrete must be adequately cured by at least 21 days minimum.

7.4 LIFT POSITIONING



Unauthorized persons are not allowed to enter during assembly.

- Transport each platform lifting system into the location or the foundation pit using hoisting means with load capacity of *1500kg* at least. To prevent the platform from dropping during transport, it should be lifted according to its centre of gravity.
- Place the control unit in the position provided for (the control unit can be place in either right side or left side).

Figure 15 – FOUNDATION PIT PLAN (only for flush mounted, with the jack beam)

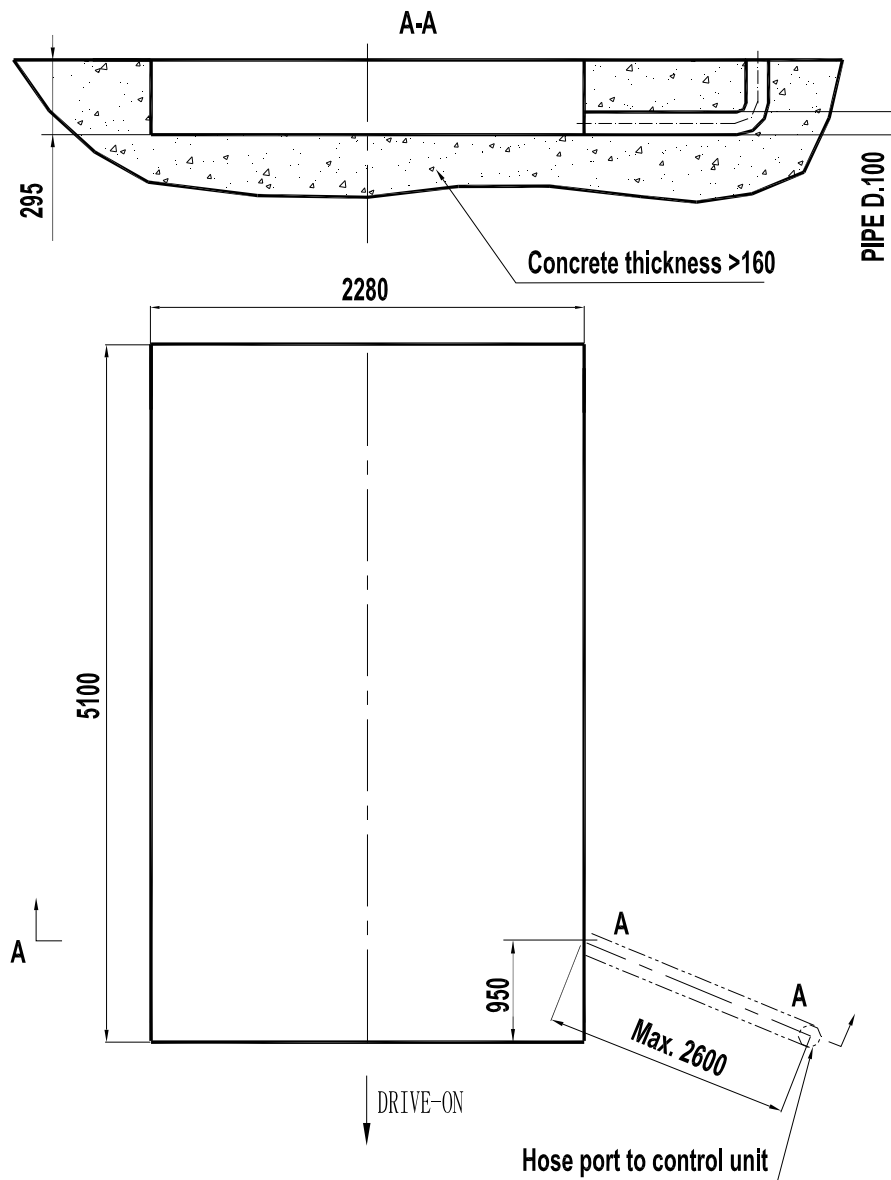

7.5 HYDRAULIC SYSTEM CONNECTION

- Place runways and jack beams at the half way with auxiliary equipment by using strong ropes, bands or chains. Be sure the runways rests on the safeties before proceeding;
- Open the front cover of the control unit;
- Following to the figure 16 route hydraulic lines referring to the letters shown on them through the pipe in the prepared foundation;
- Connect hydraulic hoses to the fittings;
- Tighten thoroughly.



When routing the hydraulic hoses, make sure that the hose is clear of any moving part, make sure to keep the hoses and fittings clean from dust. Failure to do so may result in hydraulic line failure which may result in damage or personal harm.

Figure 16 – HYDRAULIC CONNECTIONS

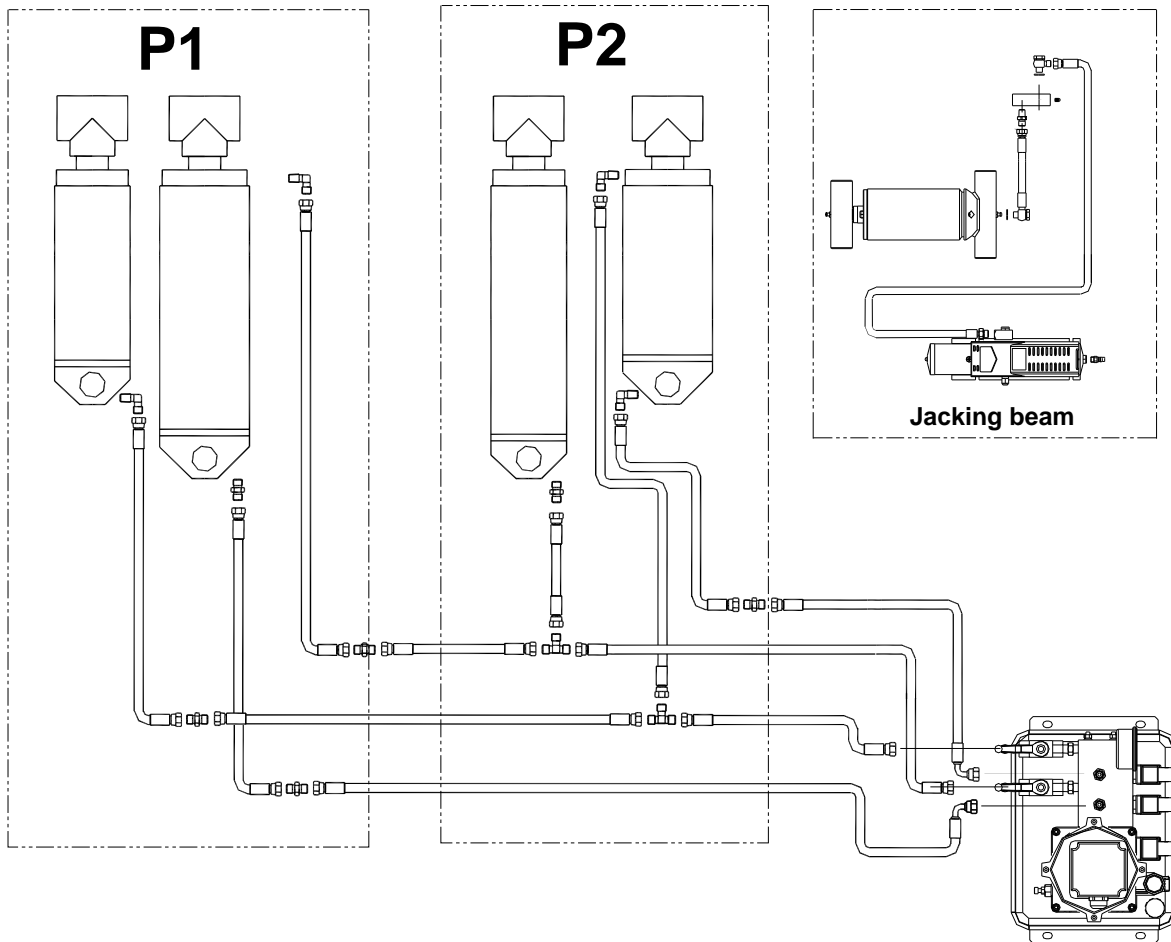

When routing the hydraulic hoses, make sure that the hoses must be clear of any moving part. Make sure to keep the hoses clean from dust.

7.6 PNEUMATIC SYSTEM CONNECTION

The pneumatic supply at site (to which the pneumatic system of the lift is connected) must be equipped with a servicing unit composed of filter, lubricator and regulator. These devices can be supplied by the manufacturer on request.

For the connection of the pneumatic lines proceed as follow:

- Connect the pneumatic lines pre-assembled on the runways to the control unit referring to the figure 17;
- Connect the pneumatic system of the lift to the pneumatic supply at site;
- Check the pneumatic control operations for proper performance.



When routing the pneumatic line, make sure that the tube is clear of any moving part. Failure to do so may result in safety failure which may result in damage or personal harm.

Figure 17 – PNEUMATIC SYSTEM CONNCETION

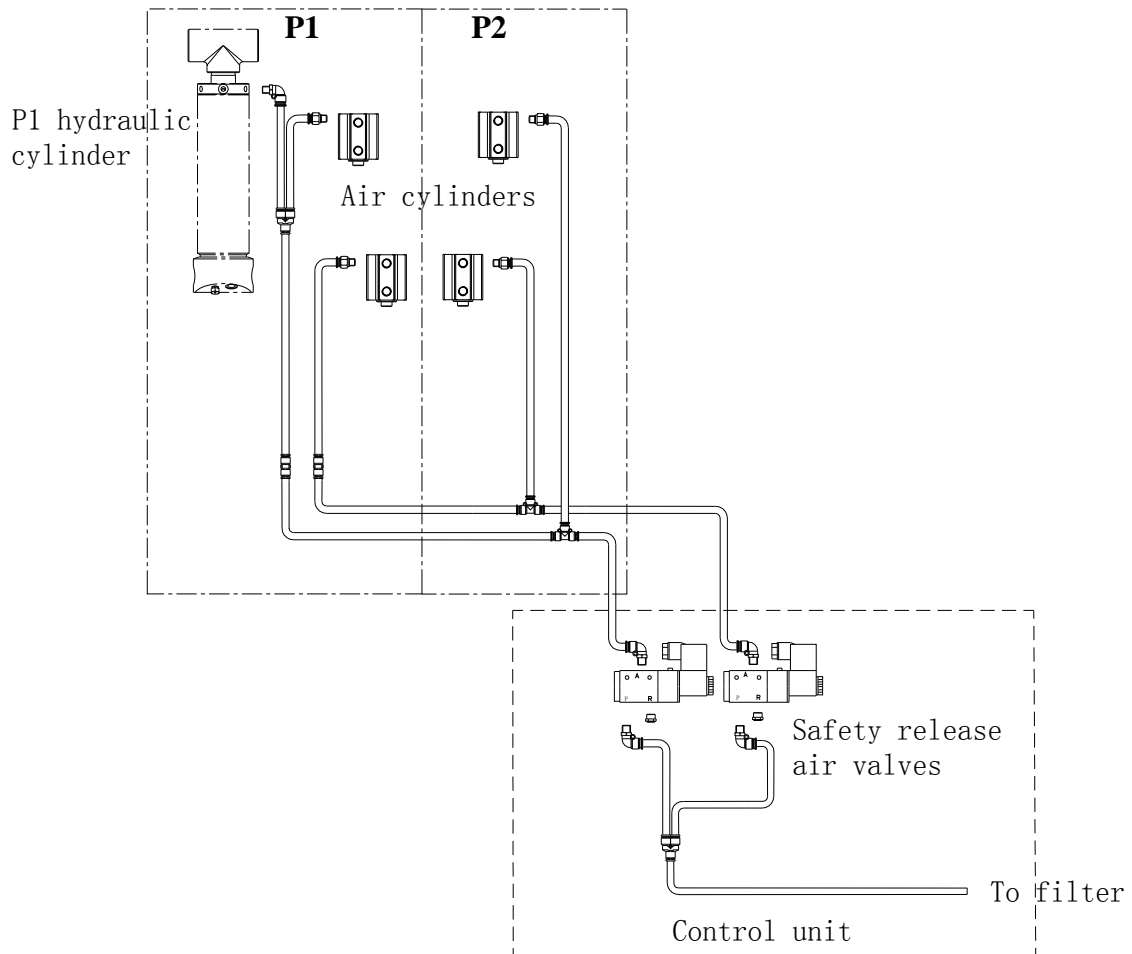

7.7 MAKE THE ELECTRICAL HOOKUP TO HYDRAULIC UNIT

	<p>The hookup work must be carried out by a qualified electrician.</p> <p>Make sure that the power supply is right.</p> <p>Make sure the connection of the phases is right. Improper electrical hook-up can damage motor and will not be covered under warranty.</p> <p>DO NOT run the hydraulic unit with no oil. Damage to pump can occur.</p> <p>The control unit must be kept dry.</p>
---	---

- Make the electric hookup to the hydraulic power unit referring to the attached wiring diagram (figure 6) using the included cables;
- Make sure the connection of the phases is right and the lift is grounded.

7.8 FEEDING OIL AND BLEEDING RUNWAYS



**Do not install the top limit switch before bleeding the hydraulic line.
During this procedure, DO NOT attempt to raise lift with any load.**

7.8.1 START

- Make sure all pins and bolts to insure proper mounting;
- Make sure the electrical system feeding voltage is equal to that specified in the nameplate on the motor;
- Make sure the electric connections are in compliant with diagrams (figure 6);
- Make sure no leakage or blow-up in hydraulic line and pneumatic line;
- Make sure the lift is grounded;
- Make sure the working area is free from people and objects;
- Grease sliding all pivot pins;
- Pour hydraulic oil into the tank (about *18 liters more than one time*);
- Verify that the control unit is powered by turning on the power switch;
- Set MAIN/JACK (fig. 18 – 1) selector into the position “”;
- Open the top cover of the control unit, set ADJ/WORK selector (fig. 18 – 2) into the position “WORK”;
- Open the front cover of the control unit, turn off both leveling cocks (fig. 19) ;

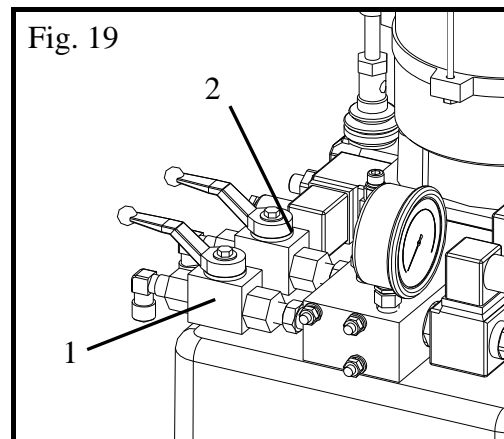
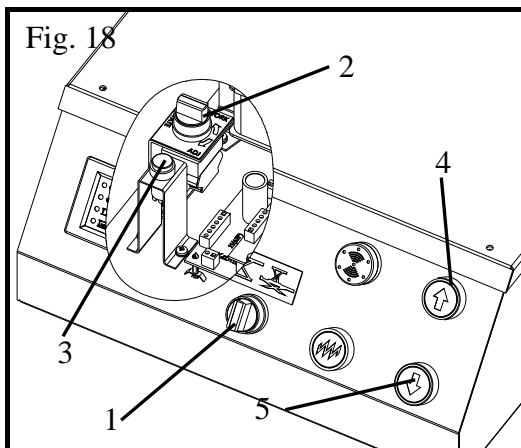

- Verify that the motor direction of rotation is that shown on the motor arrow label by pushing the lifting button. **IF MOTOR GETS HOT OR SOUNDS PECULIAR, STOP IMMEDIATELY AND RECHECK THE ELECTRIC CONNECTIONS**

7.8.2 FEEDING OIL AND BLEEDING - RUNWAYS



**Pay much attention: refill the oil if not enough during this procedure.
After bleeding, make sure to reset ordinary operating conditions. Lift cannot be lifted if a leveling cutoff cock is opened.**

- Be sure ADJ/WORK selector (fig. 18 – 2) is set into the position “WORK”;
- Press both the photocell pass-by button (fig. 18 – 3) and the lifting button (fig. 18 – 4) to fill the oil to the system: the runway P1 (the master runway: the left side from the view toward the vehicle head) is raised only in this procedure;
- Keep pressing both the photocell pass-by button and the lifting button until the runway P1 reaches the top position;

- Press both the photocell pass-by button and the lowering button (fig. 18 – 5) to lower the runway P1 completely;
- Raise the runway P1 again until it reaches the top position;
- Set ADJ/WORK selector (fig. 18 – 2) into the position “ADJ”;
- Turn on the leveling cock 1 (fig. 19 – 1);
- Press both the photocell pass-by button and the lifting button to raise the runway P2 (the slave runway: the right side from the view toward the vehicle head) until the platform reaches the top position. Pay attention to refill the oil;
- Press both the photocell pass-by button and the lowering button to lower the runway P2 completely;
- Repeat raise and lower the runway P2 completely at least 5 times;
- Raise the runway P2 to the same height as the runway P1;
- Turn off the leveling cutoff cock 1 and set ADJ/WORK selector into the position “WORK”;
- Lower and raise the runways at least 3 times to check the level of runways. If not leveled, repeat above procedure.

7.8.3 FEEDING OIL AND BLEEDING – WHEEL FREE JACKS

- Set MAIN/JACK selector into the position “”;
- Be sure ADJ/WORK selector is into the position “WORK”;
- Turn off both leveling cocks;
- Press the lifting button to fill the oil to the system: the jack P2 (the master jack on the runway P2) is raised only in this procedure;
- Keep pressing the lifting button to raise the jack P2 until it reaches the top position;
- Keep pressing the lowering button to lower the jack P2 completely;
- Raise the jack P2 again until it reaches the top position;
- Set ADJ/WORK selector into the position “ADJ”
- Turn on the leveling cock 2 (fig. 19 – 2);
- Press the lifting button to raise the jack P1 (the slave jack on the runway P1) until it reaches the top position;
- Keep pressing the lowering button to lower the jack P1 completely;
- Repeat raise and lower the jack P1 completely at least 5 times;
- Raise the jack P1 to the same height as the jack P2;
- Turn off the leveling cock 2;
- Set ADJ/WORK selector into the position “WORK” after bleeding;
- Lower and raise both jacks at least 3 times to check the level. If not leveled, repeat above procedure.

If two jacks are not in the same level after above bleeding procedure, it's possible to level them by bleeding the jack P1 (the slave jack on the runway P1) in the following way:

- Place the jack P1 at approximate 10mm height (the cylinder stroke at approximate 50mm)
- Unloose the bleeding plug (ref. fig.20) on the cylinder to let trapped air escape
- Retighten the plug after trapped air is escaped.

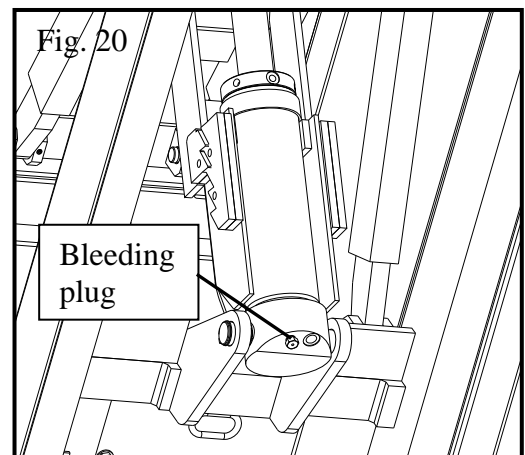



After bleeding of the lift, make sure to close all leveling cocks. Lift cannot be lifted if leveling cocks are opened.

7.9 ANCHORING AND RUNWAY ADJUSTMENT

To make an alignment of motor-vehicle, two runways should be perfectly leveled and be in the same height when resting on safeties.

For the proper adjustment of leveling accuracy proceed as follows:

- Raise the runways (without the vehicle) up to a height of about 1 meter (normal height for wheel alignment). Make sure two runways are in the same position when resting the safeties.
- Using the bases as guide, drill each hole in the concrete approximately 120mm deep with the rotary hammer drill D.16. To assure full holding power, do not ream the hole or allow drill to wobble.
- After drilling, remove dust thoroughly from each hole using compressed air or wire brush.
- Assemble the washers and nuts on the anchors then tap into each hole with a hammer until the washer rests against the bases.
- verify that both the runways are leveled horizontally by means of a water gauge or an air bubble and, if necessary, adjust in the following way until the required conditions obtained:
 - unscrew four screws (1/fig.22) on the bracket on front of scissor arm;
 - Adjust two screws (2/fig.22) up or down until two platforms are leveled perfectly;
 - Once the required conditions have been obtained, insert the shims on top of bracket as shown in the figure 22;
- With the shims and the supplied anchor bolts in place, tighten all screws and bolts.

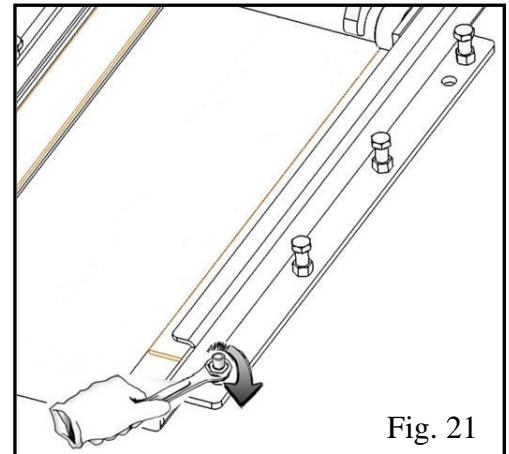

Fig. 21

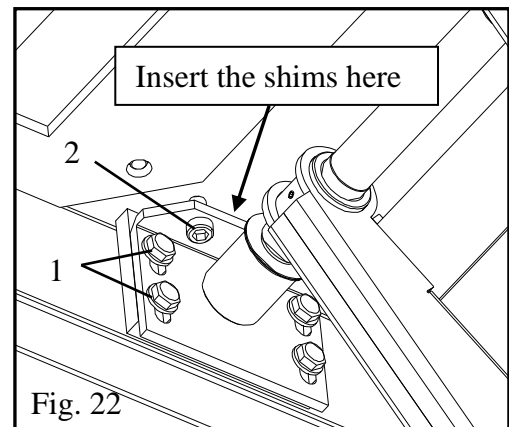

Fig. 22

7.10 INSTALLATION OF LIMIT SWITCHES (ref. fig. 23)



Only skilled personnel must be allowed to carry out this operation. An improper adjustment of limit switches could cause damages to the lift, objects and people.

7.10.1 MAX. HEIGHT LIMIT SWITCH

- Place the lift at a height of 2160 mm;
- Mount the switch (1) on the bracket;
- Raise it at a height of 2160mm to check the limit switch for proper installation;
- If the switch was not functioning properly, it's possible to adjust it by screwing the nuts of switch;
- Tighten the nuts after adjustment.
- Fix the protection cover.

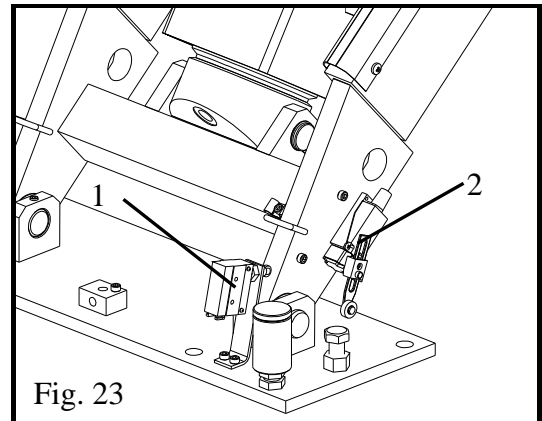

Fig. 23

7.10.2 SAFETY HEIGHT LIMIT SWITCH

- Place the lift at a desired height (400mm from the floor is suggested)
- Mount the switch (2) onto the thread holes on the arm using the included screws;
- Lower the lift at the safety height to check the limit switch for proper installation;
- If the switch was not functioning properly, it's possible to adjust it by unloosing the switch lever and changing its position;
- Tighten the screw after adjustment.
- Fix the protection cover with the supplied screws.

7.11 CHECKS LESS LOAD



During this procedure, observe all operating components and check for proper installation and adjustment. DO NOT attempt to raise vehicle until a thorough operation check has been completed.

Be sure the lift fixing to the ground and all anchor bolts tightened.
Carry out two or three complete cycles of lowering and lifting and check:

- the lift fixing to the ground and all anchor bolts tightened
- safeties for proper operation
- proper oil level in the tank
- no leakage and blow-by in hydraulic line
- cylinders for proper operation
- the level of the platforms
- the lift for reaching its maximum height
- the top limit switch for proper operation, adjust if necessary
- the safety limit switch for proper operation, adjust if necessary
- the beeper for proper operation during the final travel
- Photocells for proper operation

7.12 CHECKING WITH LOAD

Carry out two or three complete cycles of lowering and lifting and check:

- Repeat the 7.11 section
- Check no strange noise during lifting and lowering
- if the platforms or jacks weren't leveled, repeat the 7.8 section

CHAPTER 8 - OPERATION AND USE

	<p>Never operate the lift with any person or equipment below.</p> <p>Never exceed the rate lifting capacity.</p> <p>Always ensure that the safety locks are engaged before any attempt is made to work on or near the vehicle, and two platforms MUST be in equal height from the floor when resting on the safeties.</p> <p>Never leave the lift in an elevated position unless the safeties are engaged.</p> <p>If an anchor bolt becomes loose or any component of the lift is found to be defective, DO NOT USE THE LIFT until repairs are made.</p> <p>Do not permit the electric control unit to get wet!</p> <p>Pay attention to keep the photocell and the reflector clean from time to time.</p>
---	--

8.1 CONTROLS

Figure 24 – CONTROL PANEL

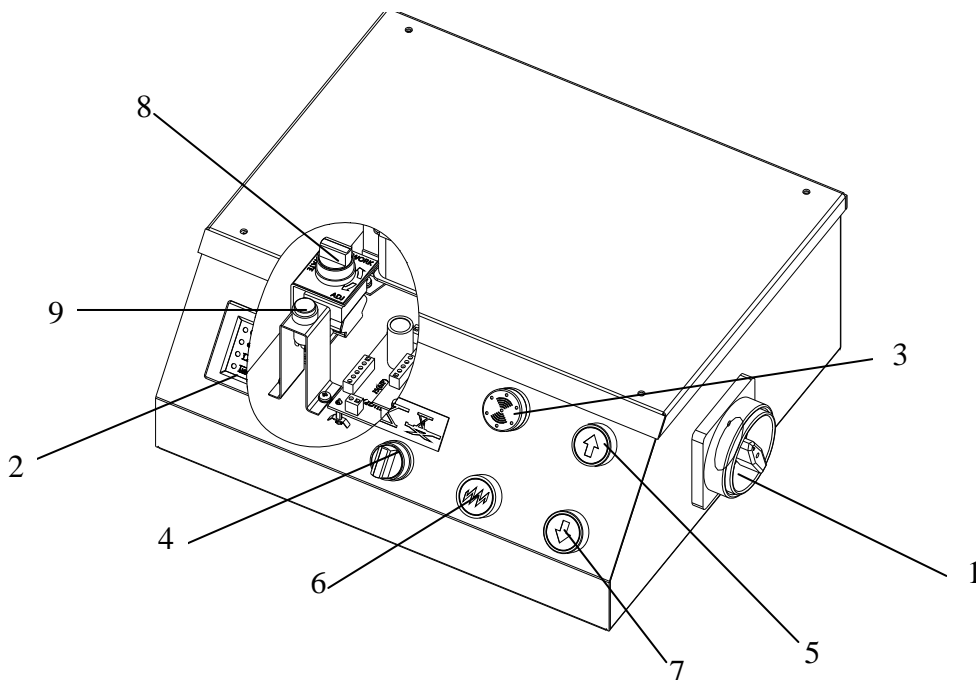

Controls for operating the lift are:









POWER SWITCH (1)

The power switch can be set in two positions:

- **0 position:** the lift electric circuit is not powered; the switch can be padlocked to prevent the use of the lift.
- **1 position:** the main electric circuit is powered.

FUNCTION INDICATOR (2)

- When ON lights, it shows that the electric circuit is powered.



- When  lights, it shows that the maximum lifting height limit is working.
- When  lights, it shows that the safety height limit switch is working.
- When  lights, it shows that the hydraulic power unit is working.
- When  lights, it shows that the runways are being operated.
- When  lights, it shows that the wheel free jacks are being operated.
- When  lights, it shows that the lift is in bleeding (ADJ) process.
-  shows the safety release time which is preset by the manufacturer if no special request.
- When  lights, it shows that the photocell is working.
- When  lights, it shows that the play detector is working if it is ordered with the lift.

BEEPER (3)

- It activates when the runways are lowered at the safety height.

MAIN/JACK SELECTOR (4)



The selector can be set in two positions:

- **Position**  : the runway circuit is powered for operation
- **Position**  : the circuit for wheel free jacks is powered for operation

LIFTING BUTTON (5)

- When pressed, the electric circuit operates the motor and hydraulic circuit to raise the runways or the wheel free jacks depending on the position the selector (4) is set.

SAFETY ENGAGING BUTTON (6)

- When pressed, the mechanical safeties on the runways start to engage the nearest racks if MAIN/JACK selector is set to the position  .
- When pressed, the mechanical safeties on the wheel free jacks start to engage the nearest racks if MAIN/JACK selector is set to the position  .

LOWERING /FINAL LOWERING BUTTON (7)

- When pressed, at first the lift takes 1-2 seconds to clear off the safety, and then descends to the safety height.
- When pressed with the lift at the safety height, the lift is lowered to the ground. A beep sound is heard during the last travel.



Be sure the safety area is free from people and objects during the final travel

ADJ/WORK SELECTOR (8)

- **Position WORK**, the lift can be for the normal operation.
- **Position ADJ**, the lift can be for bleeding operation.

PHOTOCELL PASS-BY BUTTON (9) - OPTIONAL

- When pressed, the photocell is excluded.

Lift operation can be summarized into following steps:

	<p>Make sure that two runways MUST be in equal height from the floor when resting the safeties.</p> <p>Always ensure that the safeties are engaged before any attempt is made to work on or near the vehicle.</p> <p>Make sure to engage the mechanical safety locks when the vehicle is left on the runways for long periods (ex. during the night).</p>
---	--

8.2 TO RAISE RUNWAYS

- Place the vehicle at the centre of the runways;
- Check to make sure that the vehicle is secured;
- Place pads under the positions indicated for lifting, by the motor vehicle's manufacturer;
- Set the main switch to 1 position;
- Set the main/jack selector to the position  ;
- Make sure that the leveling cocks are turned off.
- Press the lifting button to lift the vehicle to the required height;
- To rest the runways in standing position at the desired height by releasing the lifting button;
- Push the safety engaging button to engage the mechanical safeties.

8.3 TO LOWER RUNWAYS

- Be sure the safety area is free of people and objects;
- Raise the runways a little bit by pushing the lifting button to clear off the mechanical safeties;
- Press the lowering button: the runways will take seconds to release the safeties and then begins to descend lower under its weight and the load lifted.
- Keep pressing the lowering button until the runways are lowered to the safety height;
- Press the lowering button again at the safety height until the runways are lowered completely. A beep sound is heard during the last travel.

8.4 TO RAISE WHEEL FREE JACKS

- Place the rubber blocks under the picking point at the car. Adjust jack table extensions according to vehicle to lift if necessary;
- Check to make sure that the vehicle is secured;
- Place pads under the positions indicated for lifting, by the motor vehicle's manufacturer;
- Set the main/jack selector to the position  ;
- Press the lifting button to lift the vehicle to the required height;
- To rest the jacks in standing position at the desired height by releasing the lifting button;
- Push the safety engaging button to engage the mechanical safeties.

8.5 TO LOWER WHEEL FREE JACKS

- Be sure the safety area is free of people and objects;
- Raise the jacks a little bit by pushing the lifting button to clear off the mechanical safeties;
- Press the lowering button: the jacks will take seconds to release the safeties and then begins to descend lower under its weight and the load lifted.
- Keep pressing the lowering button until the jacks are lowered completely.

8.6 RUNWAY LEVELING



During this procedure, DO NOT attempt to raise lift with any load. Pay attention not to stand in front of the photocell when lifting or lowering the lift.

After a period of service, due to natural loss of the oil or trapped air in the hydraulic line, it could be possible that the runway P2 (the slave runway) is lower than the runway P1 (the master runway). In this case, level the runways following these instructions:

- Raise the runways at approximate 300mm;
- Set ADJ/WORK selector into the position “ADJ”;
- Turn on the leveling cock 1 (ref. fig. 19);
- Feather-pushing the lifting button/the lowering button and in the meantime press the photocell pass-by button to adjust the height of the runway P2;
- Turn off the leveling cock 1 after the runway P2 reaches at the same height as the runway P1;
- Set ADJ/WORK selector into the position “WORK” after the adjustment.

8.7 MANUAL EMERGENCY LOWERING

In case of an emergency (power failure), the lift can be lowered manually to its initial position as follows referring to the figure 25:

- Padlock the power switch;
- Open the front cover of the control unit;

8.7.1 TO LOWER RUNWAYS MANUALLY

- Set the MAIN/JACK selector to “”;
- If the mechanical safeties are engaged, keep pushing the slider (3) of the solenoid valve using a proper pin;
- Operate the emergency hand pump (1) to raise the runways a little bit to clear off the mechanical safeties.
- Referring to the pneumatic diagram (figure 17) to locate the solenoid air valve for the runways, keep pressing the emergency button on the valve;
- Unloosen the emergency screw (2) of the lower solenoid valve by turning it anticlockwise and in the meantime keep pushing the slider (3) until the runways are lowered completely;
- Retighten the emergency screw (2) by turning it clockwise after the runways are lowered.

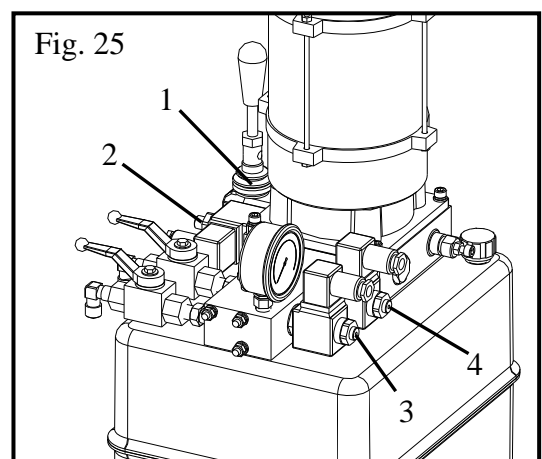

When a mechanical safety is released, it is advised to use a carton board to put between the safety pawl and the rack to avoid it from engaging. In this case, do not need to press the emergency button continuously. Screwing or unloosing the emergency screw can reduce or increase the lowering speed

8.7.2 TO LOWER WHEEL FREE JACKS MANUALLY

- Set the MAIN/JACK selector to “”;
- If the mechanical safeties are engaged, keep pushing the slider (4) of the solenoid valve using a proper pin;
- Operate the emergency hand pump (1) to raise the jacks a little bit to clear off the mechanical safeties.
- Referring to the pneumatic diagram (figure 17) to locate the solenoid air valve for wheel free jacks, keep pressing the emergency button on the valve;
- Unloosen the emergency screw (2) of the lower solenoid valve by turning it anticlockwise and in the meantime keep pushing the slider (4) until the jacks are lowered completely;
Retighten the emergency screw (2) by turning it clockwise after the jacks are lowered.



After manual lowering of the lift, reset ordinary operating conditions. Lift cannot be lifted if unloading valve is opened.

8.8 OPERATION OF JACK BEAM (optional)

The jack beam is to be operated by an air-hydraulic pedal pump supplied with the lift.

Figure 26 - JACK BEAM CONTROLS

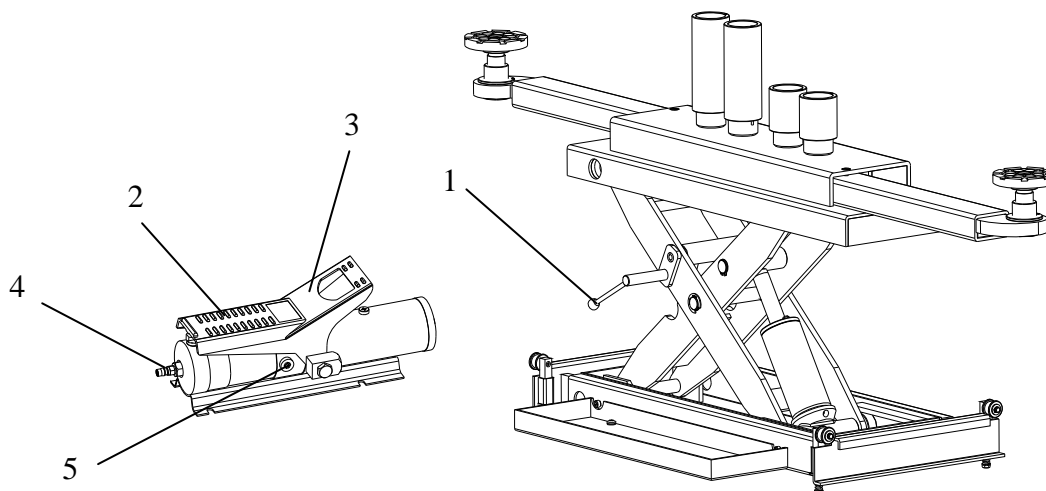

SAFETY LEVER (1)

- When is up, the jack safety is released.
- When is down, .the jack safety can be locked.

LIFTING PEDAL (2)

- When pressed, the hydraulic fluid is started to be delivered from the oil reservoir of the pump into the jack cylinder: the jack beam begins to rise.

LOWERING PEDAL (3)

- When pressed, the hydraulic fluid is started to be released from the jack cylinder into the oil reservoir of the pump: the jack beam begins to descend under the weight loaded.
- The lowering speed can be controlled by change of the foot pressing force on the pedal.

AIR HOSE FITTING (4)

- It is to be connected with the air hose to the compressed air. .

FLUID PORT(5)

- It is to be connected with the hydraulic hose from the pump to the jack beam cylinder.

8.8.1 TO RAISE THE JACK BEAM



Never raise the jack beam over high than the rated height. The manufacturer will not be responsible for the damage because of the incorrect operation.

- Check to be sure the hydraulic hose and the air hose are connected properly;
- Check to be sure the oil in the pump tank is sufficient.
- Adjust arm extensions according to vehicle.
- Adjust the lifting adaptor height properly. If necessary, place the appropriate extensions on the lifting adaptors.
- Make sure the vehicle is secured;
- Raise the jack by depressing the lifting pedal on the pump.

8.7.2 STANDING

- To rest the vehicle at the desired height by releasing the lifting pedal;
- Place the safety pawl on the nearest safety rack by set the safety lever down;
- Lower the jack beam by depressing the lowering pedal on the pump to engage the safety.
- Check to make sure the mechanical safety is engaged before entering the work area.

8.7.3 TO LOWER THE JACK BEAM

- Be sure the under jack is free of any objects;
- Raise the jack beam a little bit by depressing the lifting pedal;
- Release the mechanical safety by set the safety lever up;
- Depressing the lowering pedal on the pump until the jack beam is lowered completely.

CHAPTER 9 - MAINTENANCE



Only trained personnel who knows how the lift works, must be allowed to service the lift.

To service properly the lift, the following has to be carried out:

- use only genuine spare parts as well as equipment suitable for the work required;
- follow the scheduled maintenance and check periods shown in the manual;
- discover the reason for possible failures such as too much noise, overheating, oil blow-by, etc.

Refer to documents supplied by the dealer to carry out maintenance:

- functional drawing of the electric and hydraulic equipment
- exploded views with all data necessary for spare parts ordering
- list of possible faults and relevant solutions.



Before carrying out any maintenance or repair on the lift, disconnect the power supply, padlock the general switch and keep the key in a safe place to prevent unauthorized persons from switching on or operating the lift.

9.1 ORDINARY MAINTENANCE

The lift has to be properly cleaned at least once a month using self-cleaning clothes. Lubricate all pivot pins at least once a week.



The use of water or inflammable liquid is strictly forbidden.

Be sure the rod of the hydraulic cylinders is always clean and not damaged since this may result in leakage from seals and, as a consequence, in possible malfunctions.

9.2 PERIODIC MAINTENANCE

Every 3 months	Hydraulic circuit	<ul style="list-style-type: none"> ▪ check oil tank level; refill with oil, if needed; ▪ check the circuit for oil leakage. ▪ check seals for proper conditions and replace them, if necessary;
	Foundation bolts	<ul style="list-style-type: none"> ▪ check bolts for proper tightening
	Hydraulic pump	<ul style="list-style-type: none"> ▪ verify that no noise changes take place in the pump when running and check fixing bolts for proper tightening
	Safety system	<ul style="list-style-type: none"> ▪ check safety devices for proper operation
Every 6 months	Oil	<ul style="list-style-type: none"> ▪ check oil for contamination or ageing. Contaminated oil is the main reason for failure of valves and shorter life of gears pumps
Every 12 months	General check	<ul style="list-style-type: none"> ▪ verify that all components and mechanisms are not damaged
	Electrical system	<ul style="list-style-type: none"> ▪ a check of the electrical system to verify that motor, limit switch and control panel operate properly must be carried out by skilled electricians
	Oil	<ul style="list-style-type: none"> ▪ empty the oil tank and change the hydraulic oil

CHAPTER 10 – TROUBLESHOOTING

A list of possible troubles and solutions is given below:

TROUBLE:	POSSIBLE CAUSE:	SOLUTION:
	The power switch is not turned on	Turn the switch on
The lift does not work	There is no power	Check power and restore if necessary
	The electrical wires are disconnected	Replace
	Fuses are blown	Replace
	The one of limit switches is faulty.	Check the switch and relevant connection for proper operation. Replace, if needed.
The lift does not raise when the lifting button is pressed	The motor direction of rotation is not correct	Interchange the phases on the main switch
	The oil in the hydraulic unit is not sufficient	Add some hydraulic oil
	The lifting button is faulty	Check the lifting button and connection for proper operation. Replace, if needed
	The lowering solenoid valve does not close	Check and clean, if dirty, or replace, if faulty
	The emergency screw of lowering valve does not close	Retighten the screw
	The suction pump filter is dirty	Check and clean if needed
	The photocell sees an obstacle as a consequence does not read	Remove the obstacle
	The reflector is defective as consequence the photocell does not read	Replace the reflector
	The platforms aren't leveled and as consequence photocell does not read	Level the platforms
	The photocell isn't correctly positioned as consequence does not read	Restore the correctly position
The lift does not lower when the lowering button is pressed	The motor does not operate properly and does not release the mechanical safeties	Check the motor
	The lift goes up instead of going down	
	-Because solenoid air valve is faulty	Replace air solenoid valve
	-Because the air does not reach the circuit	Verify the compressor and air hose ability
	-Because electric board is faulty	Replace electric board
	The lowering solenoid valve does not discharge	Verify if it is powered and check the magneto for damages (replace if disconnected or burnt)
	The lowering solenoid valve is not operating	Verify if it is powered and check the magneto for damages (replace if disconnected or burnt)
	The lowering button is faulty	Check the lowering button and

		connection for proper operation. Replace, if needed
	The photocell sees an obstacle as a consequence does not read	Remove the obstacle
	The reflector is defective as consequence the photocell does not read	Replace the reflector
	The platforms aren't leveled and as consequence the photocell does not read	Level the platforms
	The photocell isn't correctly positioned as consequence does not read	Restore the correct position
The lift does not stop at the safety height	The safety height limit switch is not adjusted correctly or it is faulty	Adjust or change the limit switch
	The electric board is faulty	Replace electric board
	The motor does not operate properly and does not release the mechanical safeties	Check the motor
	The lowering button is faulty	Check the lowering button and connection for proper operation. Replace, if needed
The lift isn't raising synchronous	Presence of air or dripping in the hydraulic circuit	Bleed the hydraulic circuit
	The cylinder gaskets can be damaged	Check and replace if necessary
The lifting capacity is not sufficient	The oil in the tank is not enough	Fill oil in the tank
	The pump is faulty	Check the pump and replace if necessary
	The maximum pressure valve is not adjusted correctly	Adjust correctly
The lift does not lift or lower smoothly	Leakages or presences of air into hydraulic circuit	Bleed the hydraulic system
The motor does not stop when reaching it maximum height	The top limit switch does not work	Check the limit switch and replace if needed
The lift does not lift or lower smoothly	Leakages or presences of air into hydraulic circuit	Bleed the hydraulic system
	The pump filter is dirty.	Check and clean if needed.
	The pump suction is blown	Check the seal and replace if needed